

Conprofe Ultrasonic Tool Holder + Conprofe Solid PCD Micro-edge Flat End Mill

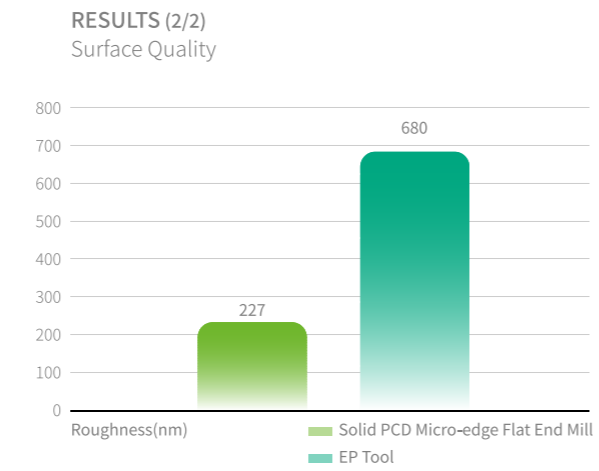

RESULTS (1/2)

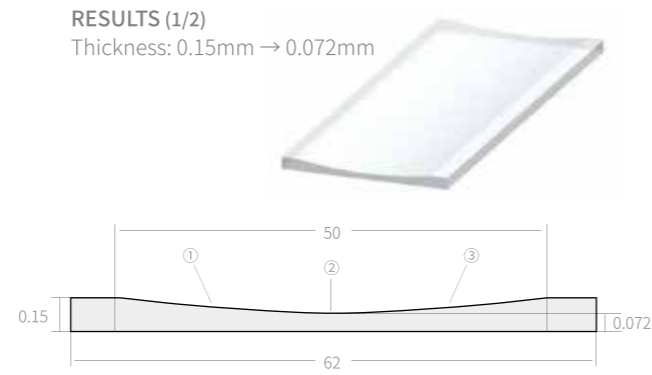
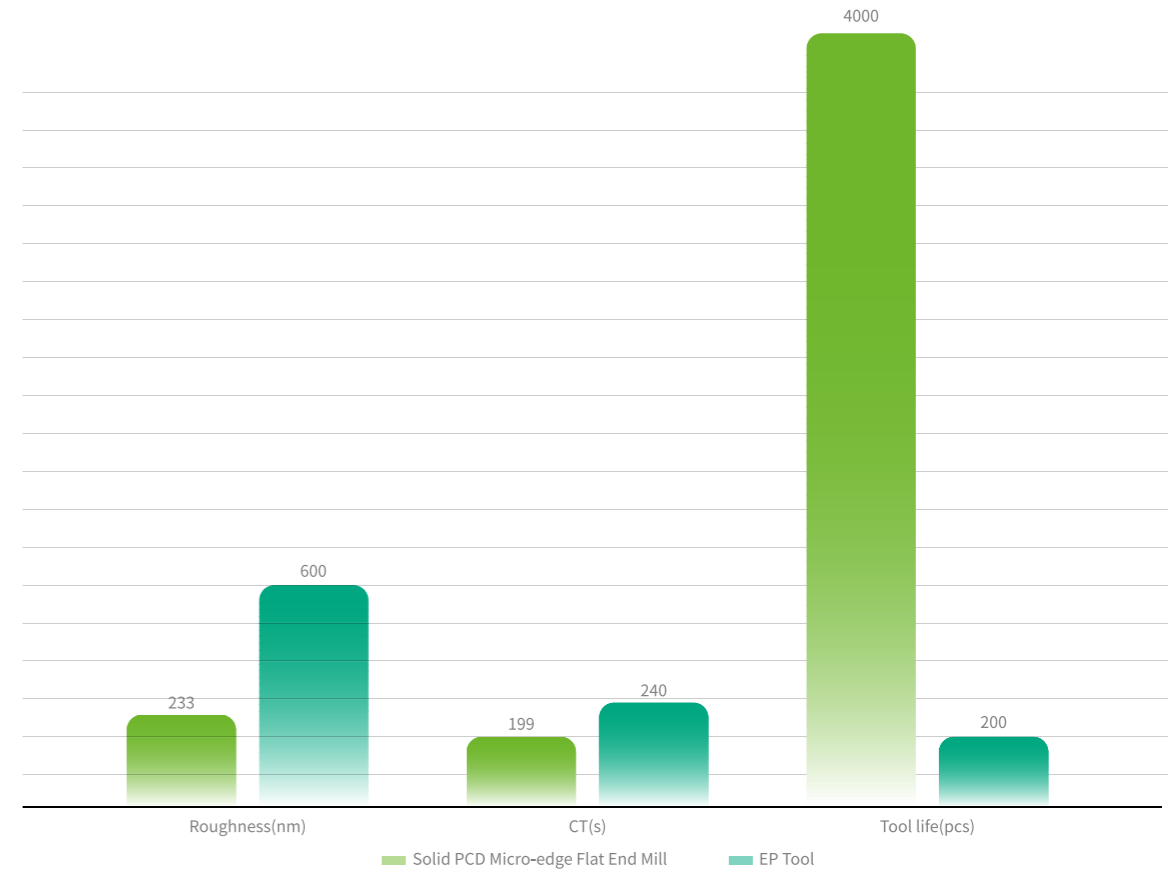

Conprofe Solid PCD Micro-edge Profiling End Mill

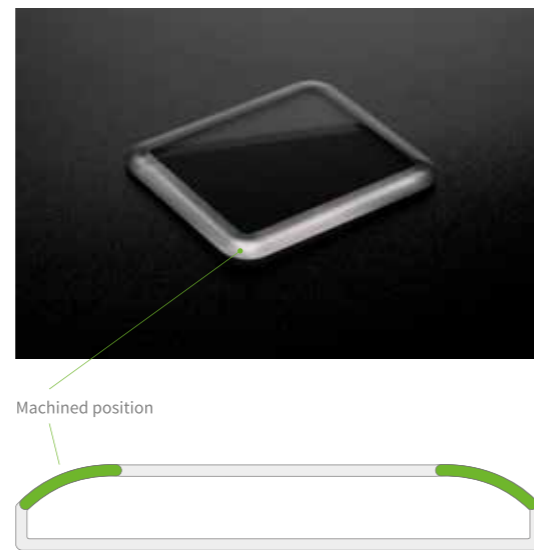

RESULTS (2/2)

Roughness ≤ 400 nm

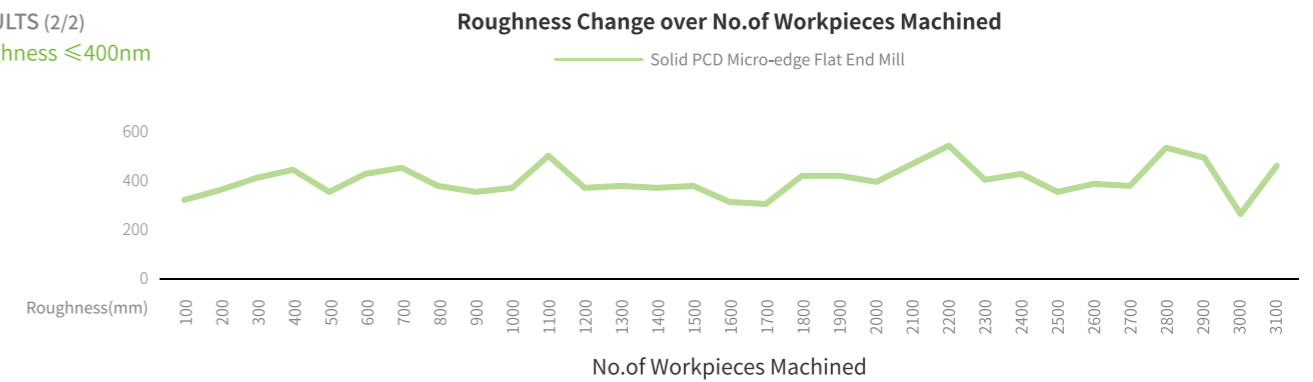

Profile Deviation ≤ 0.02 mm

